

# LUMISYS

BUILT FOR INTEGRATION

Lumisys LVS



Installation Guide

**ATTENTION**

This section serves as a notice of the immediate or potential dangers involved when working with the equipment described throughout this manual. Any person involved in installation, maintenance, or service of the equipment should first carefully examine the equipment and read the instructions contained in this manual to ensure that personal and/or equipment injury is avoided.

The following safety messages are used throughout this manual to alert of immediate or potential danger to life or property:



**Hint** Indicates a tip or trick to help you.



**Note** Indicates an important note.



**DANGER!** Indicates an immediately hazardous situation which, if not avoided, will result in death or serious injury.



**WARNING!** Indicates a potentially hazardous situation which, if not avoided, can result in death or serious injury.



**CAUTION:** Indicates a potentially hazardous situation which, if not avoided, can result in minor or moderate injury.

**CAUTION:** Used without the safety alert symbol, indicates a potentially hazardous situation which, if not avoided, can result in personal or property damage. Failure to comply with proper handling of the Lumisys products may void your warranty



In addition, this symbol may appear in the margin of specific portions of text as a safety reminder. Applicable instruction steps will be listed beneath the symbol.

**Disclaimer**

This equipment has been tested and found to comply with the limits for a Class A digital device, pursuant to part 15 of the FCC Rules. These limits are designated to provide reasonable protection against harmful interference when the equipment is operated in a commercial environment. This equipment generates, uses, and can radiate radio frequency energy and, if not installed and used in accordance with the instruction manual, may cause harmful interference to radio communications. Operation of this equipment in a residential area is likely to cause harmful interference, in which case the user will be required to correct the interference at his own expense.

Instructions contained in this user's guide should be performed only by qualified persons in accordance with local and national codes. Lumisys® Lighting and its affiliates assume no responsibility for any consequences related to the improper use of this manual.

REQUEST COMMISSIONING

### Table of Contents

<b>Parts List</b> .....	<b>4</b>
<b>Installation</b> .....	<b>5</b>
Connect to Lighting Panel .....	5
Typical Wiring .....	5
Convert to Single Button Style .....	6
<b>Terms and Conditions of Sale</b> .....	<b>7</b>

### LVS

#### Parts List

LOW VOLTAGE KEY SWITCH				
Part #	Description	Contact Type	Finish	Panel Switch Inputs Required
LVS	2 Button, Low voltage switch	Momentary	White Plastic	2 + 1 Common Ground
257112	Optional: Frame, switch, single button (conversion frame)	N/A	White Plastic	N/A



Front

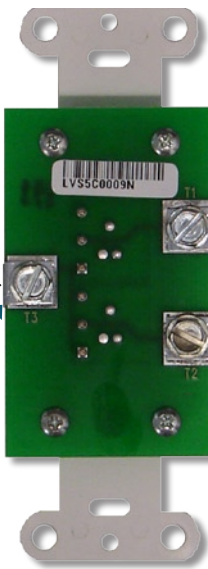

Back

Common  
Slot or nut driven  
screws with  
washer flange

Terminal for  
upper button

Terminal for  
lower button



#257112

Optional  
conversion  
frame

#### LV-SW Product Description

White  
Single Gang  
Two-Button Switch  
Includes switch and frame (does not include wall plate)

#### Optional Conversion Frame (Part #257112)

White  
Single Gang  
Single-Button Conversion Frame  
Converts any LVS to a Single-Button Switch

### Installation

#### Connect to Lighting Panel



Front

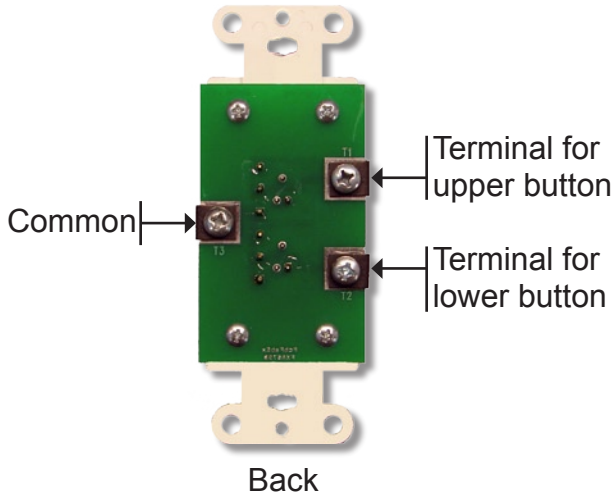

### Typical Wiring

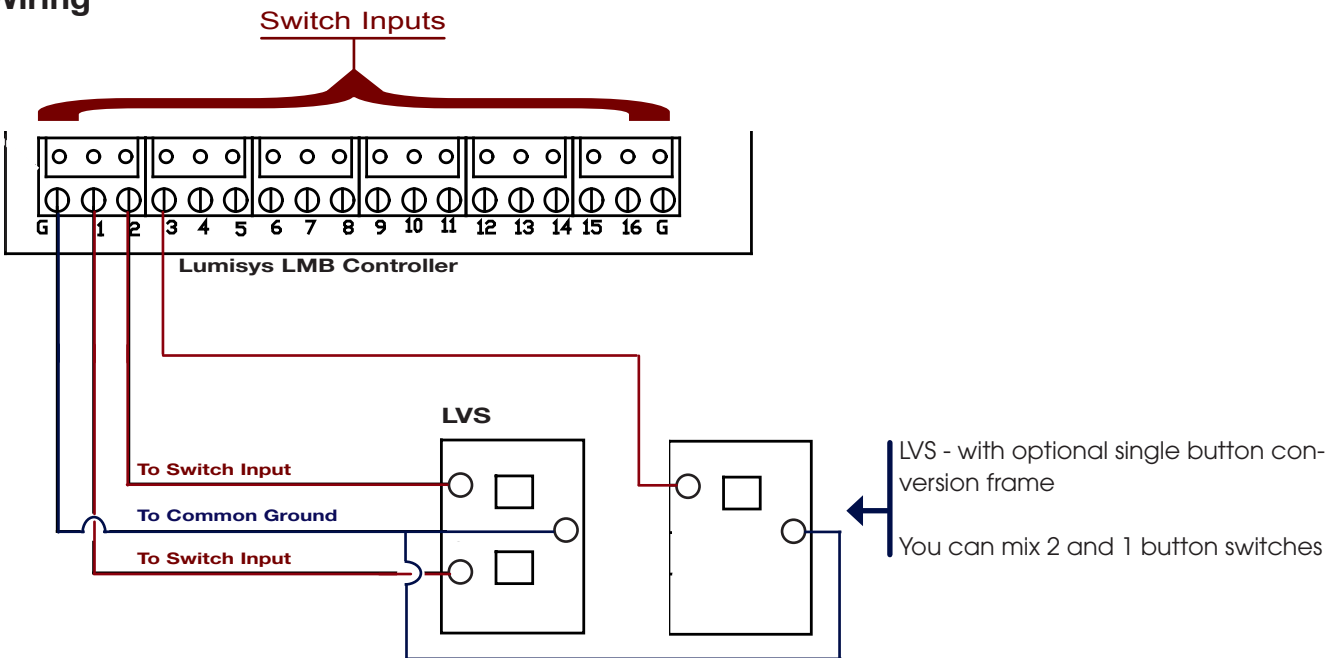

## Installation

### Convert to Single Button Style

#### Step 1

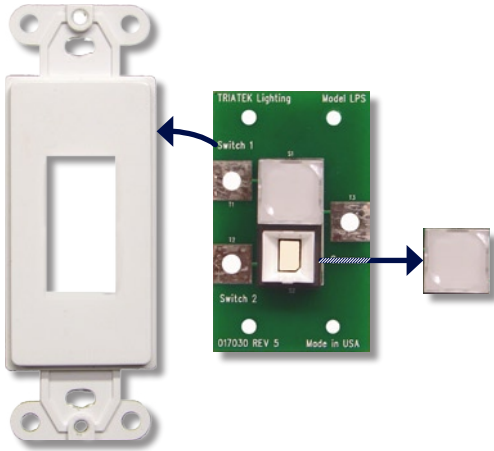

Remove 2-button frame and lower clear cap from the circuit board

#### Step 2

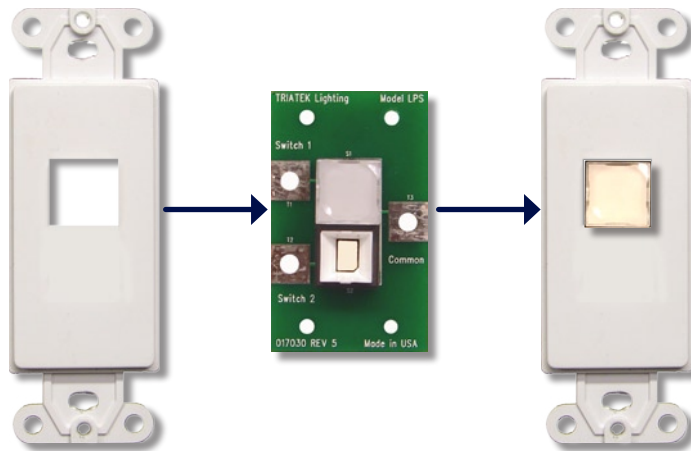

Attach the 1-button frame\* to the circuit board  
\* 1-button frame ordered separately - part # 257112

## Terms and Conditions of Sale

**AGREEMENT OF SALE:** Acceptance by Lumisys, (hereinafter "Seller") of any order, placed for the goods described on the Acknowledgment, Invoice or Sales Contract hereof shall be subject to Seller's Standard Terms and Conditions of Sale and is conditioned upon the Buyer's acceptance of these Standard Terms and Conditions of sale as stated on this Sales Contract.

**TERMS OF CONTRACT:** Any terms or conditions of the Buyer's order which are inconsistent with these Standard Terms and Conditions shall not be binding on the Seller and shall not be considered applicable to the sale or shipment of goods covered by this Acknowledgment, Invoice, or Sales Contract. **PRICES:** Prices are subject to change to the extent permissible under applicable federal law. Sales contracts which call for delivery in the future will be billed at prices in effect at the time of shipment. Shipping weights shown are approximate and subject to change without notice. Seller shall notify buyer of any significant changes in weight.

**SHIPMENT AND PAYMENTS:** All prices are F.O.B. Seller's plant in Kennesaw, Georgia. No freight is allowed on any shipments. Shipments and deliveries hereunder shall at all times be subject to the approval of Seller's Credit Department. Seller may, at any time, require payment in advance or satisfactory security or guarantee that invoices will be promptly paid when due. If Buyer fails to comply with any terms of payment, Seller, in addition to its rights and remedies but not in limitation thereof, reserves the right to withhold further deliveries or terminate this Agreement, and any unpaid amount thereon shall become due immediately. Terms of payment shall be as set forth on the face hereof. Unless approved by Seller, all overseas shipments shall require prepayment by wire transfer or an irrevocable letter of credit from Buyer.

**FORCE MAJEURE:** Delays or defaults in delivery by Seller of the goods covered by this Sales Contract shall be excused as Force Majeure so far as the same is caused by fire, strikes, accident, war, natural disasters, acts of God, terrorism, explosions, death, vandalism, armed robbery, theft, breakage of machinery, governmental regulation, or any other events which were unavoidable or caused by events which are beyond the reasonable control of Seller. In no event shall Seller be liable for any consequential, special, or contingent damages on account of any default or delay in delivery from any Force Majeure event. If any Force Majeure event occurs which may affect Buyer's goods, Seller shall give prompt oral and written notice of its Force Majeure declaration to Buyer within 7 days or as soon as is practicable.

**NON-CANCELLATION:** Orders are not subject to suspension, reduction, or cancellation, except on terms that will indemnify Seller against loss. **SPECIFICATIONS:** Seller relies on specifications and other data furnished by the Buyer, architect, contractors, and/or consulting engineer in all phases of the work covered by this Acknowledgment, Invoice or Sales Contract. Seller shall be responsible to check quantities only. Alterations, changes in specifications, approval of samples, and/or changes in delivery shall not be binding upon Seller unless approved by Seller in advance. In the event Buyer asks Seller to perform design or engineering work for any and all phases of the work covered by this Acknowledgment, Invoice or Sales Contract, Seller shall not be responsible for any damages claimed by the Buyer as a result of alleged errors or defects in such design or engineering work except for gross negligence on the part of Seller.

**WARRANTY AND LIMITATION OF LIABILITY:** Seller warrants that the goods supplied by it have been manufactured in accordance with its standard manufacturing practices, are non-defective and conform to the contract or catalog description for such goods. Except as stated herein, Seller makes no express warranty with respect to goods supplied by it and Seller makes no implied warranties of suitability or fitness for any particular purpose. Unauthorized or unapproved modifications or alterations of such goods without the express written approval of Seller shall void all warranties and indemnities granted herein. To satisfy its indemnity and warranty obligations, Seller will, at its sole option, credit, repair or replace, any goods supplied by it which its examination shall disclose to its satisfaction are defective in workmanship or material, and are returned to it within two years from the date of shipment. Any claim not made within this period shall be conclusively deemed waived by Buyer. Seller shall not be liable for any consequential, special, incidental, punitive or contingent damage or expense arising directly or indirectly from any defect in its goods or from the use of any defective goods or otherwise arising out of this Contract or any purchase order. The remedies set forth herein shall constitute the exclusive remedies available to Buyer for Seller's indemnity and warranties and are in lieu of all other remedies that would otherwise be available to Buyer.

Warranty and technical support on Lumisys products are only available after payment has been received in full.

**RETURNS:** Material returned for credit is subject to a 10% restocking charge. Freight or other costs incurred in restocking will be added. Returns resulting from errors by the Seller will not be subject to the charge. Returned materials shall be received in condition for resale as new equipment to qualify for credit. Returned materials must be returned to the Seller within 30 days of receipt and shall only be accepted with prior authorization.

**SELLER RESERVES THE RIGHT TO SUBSTITUTE MATERIALS USED IN CONSTRUCTION OR EQUIPMENT SOLD PROVIDED SAID SUBSTITUTION DOES NOT MODIFY THE OPERATIONAL CHARACTERISTICS OF THE EQUIPMENT SOLD.**

**THESE TERMS OF SALE MAY BE MODIFIED WITHOUT NOTICE. THE TERMS OF SALE IN EFFECT AT THE TIME OF SALE SHALL APPLY. THE SELLER AS REFERRED TO IN THE TERMS OF SALE IS Lumisys.**

**CLAIMS:** Claims for shortages of goods or for mistakes or errors in billing must be presented within forty-five (45) days from the date of goods; and must state the packing slip number and container number applicable to the claim. Any claim not so presented shall be conclusively deemed waived.

**TAXES:** Any federal, state, local or government tax or charge on the sale, shipment, or installation of the goods covered by the Acknowledgment, Invoice or Sales Contract, shall be added to the price and paid by Buyer or, in lieu thereof, the Buyer shall furnish Seller with tax-exemption certificates acceptable to the taxing authority. Buyer agrees to reimburse and save Seller harmless from all such state and local taxes, including interest and penalties thereon, which may at any time be payable to any governmental unit with respect to the sale of any goods covered by this Acknowledgment, Invoice or Sales Contract.

**CREDIT BALANCE:** Any credit memos granted to Buyer from Seller arising out of returned goods or other circumstances, which are not subsequently requested or applied to the purchase of other goods from Seller within twelve months from the date credit was granted, shall become the property of Seller.

**APPLICABLE LAW:** All questions arising out of this Acknowledgment, Invoice or Sales Contract, which shall be deemed a Georgia contract, shall be governed by the laws of the State of Georgia. Venue for any disputes arising out of this agreement shall be in Georgia. All disputes arising out of this agreement shall be resolved in the following fashion: the parties shall first engage in good-faith negotiation. If the parties are unable to settle their claims through good-faith negotiation, the parties shall attempt to resolve their dispute through mediation by an agreed upon mediator. Lastly, if mediation fails, the parties shall be subject to binding arbitration by an agreed upon arbitrator who is a member of the American Arbitration Association. The prevailing party in any arbitration or other legal action arising out of this agreement, and/or these terms and conditions of sale, shall be entitled to indemnification of all its attorneys' fees, litigation expenses, and costs from the losing party.

**EXCLUSIVE TERMS:** This Acknowledgment, Invoice or Sales Contract, which includes these Standard Terms and Conditions, shall constitute the final and binding contract between the parties and shall take precedence over any other terms and conditions from the Buyer. Any changes or deviations from this Acknowledgment, Invoice or Sales Contract must be in writing and mutually agreed to by Buyer and Seller.

**LIMITATION FOR SUITS:** Any controversy or claim arising out of, or relating to, this Acknowledgment, Invoice or Sales Contract, or the breach thereof, must be commenced within two (2) years